

# SVÄNGKRAN

## TYP GBP-T/GBA-T



**LYFTTEMA AB**

Arvidstorp, 640 25 Julita

Tel: 016-801 25 Fax: 016-801 26

[www.lyfttema.se](http://www.lyfttema.se) [info@lyfttema.se](mailto:info@lyfttema.se)

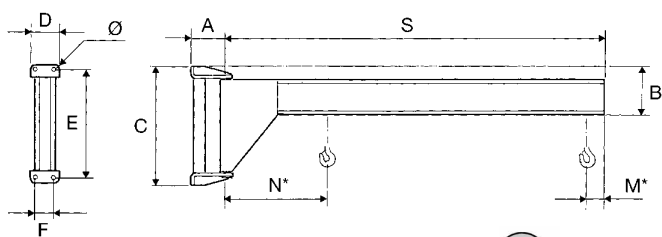
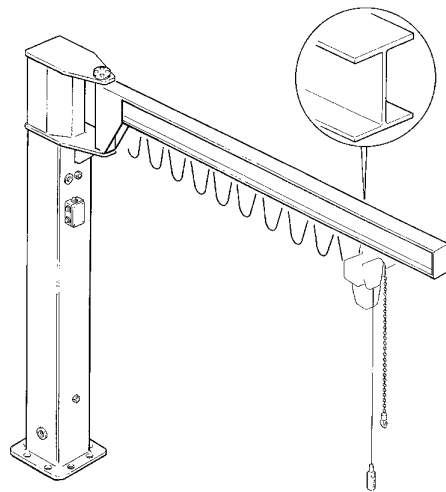
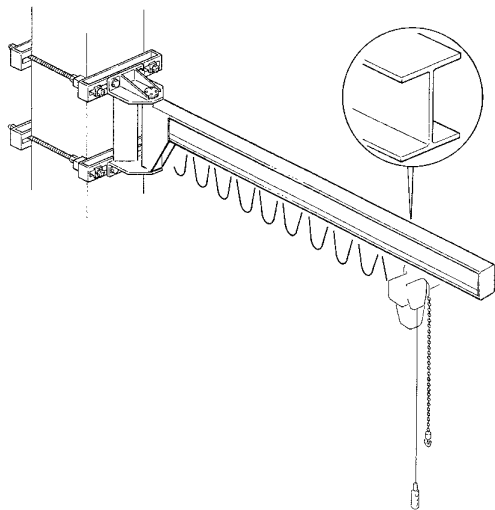

Vägsvängkran - aktionsområde 250°

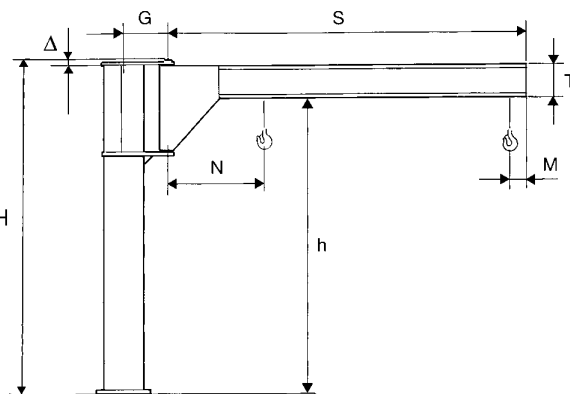

Pelarsvängkran - aktionsområde 290°

Last kg	Arm längd mm		Storlek pelare mm
	S	m	
63	4	A	A
	5	A	
125	2	A	B
	3	A	
	4	B	
	5	B	
250	2	B	C
	3	B	
	4	C	
	5	C	
500	2	C	D
	3	C	
	4	D	
	5	D	
	2	D	
1000	3	D	E
	4	E	
	5	E	
	2	E	
	3	E	
2000	2	E	E
	3	E	

GBP vägsvängkran typ T									
Typ	Mått i mm								Kranvikt kg
	A	B	C	D	E	F	Ø		
T01A40	170	248	644	200	594	150	15	95	
T01A50	170	248	644	200	594	150	15	111	
T01A20	170	248	644	200	594	150	15	63	
T01A30	170	248	644	200	594	150	15	79	
T01B40	170	288	644	200	594	150	15	125	
T01B50	170	288	644	200	594	150	15	147	
T01B20	170	288	644	200	594	150	15	81	
T01B30	170	288	644	200	594	150	15	103	
T02C40	210	346	930	250	870	190	22	195	
T02C50	210	346	930	250	870	190	22	226	
T02C20	210	346	930	250	870	190	22	134	
T02C30	210	346	930	250	870	190	22	165	
T02D40	210	406	930	250	870	190	22	256	
T02D50	210	406	930	250	870	190	22	298	
T02D20	210	406	930	250	870	190	22	172	
T02D30	210	406	930	250	870	190	22	214	
T03E40	255	499	1240	300	1160	220	34	381	
T03E50	255	499	1240	300	1160	220	34	438	
T03E20	255	499	1240	300	1160	220	34	267	
T03E30	255	499	1240	300	1160	220	34	324	

GBA pelarsvängkran typ T									
Total höjd H* m	Typ	Under balk h	Mått i mm					Vikt	
			G	M	N	T (PE)	Δ	Arm kg	Pelare kg
3	T30A40	2800	220	180	640	160	12	145	18
3	T30A50	2800	220	180	700	160	12	161	18
3	T30A20	2800	220	180	580	160	12	113	18
3	T30A30	2800	220	180	640	160	12	129	18
3	T30B40	2760	255	180	680	200	12	207	28
3	T30B50	2760	255	180	740	200	12	229	28
3	T30B20	2760	255	180	620	200	12	163	28
3	T30B30	2760	255	180	680	200	12	185	28
3.5	T35C40	3212	310	180	740	240	17	313	34
3.5	T35C50	3212	310	180	800	240	17	344	34
3.5	T35C20	3212	310	180	680	240	17	252	34
3.5	T35C30	3212	310	180	740	240	17	283	34
3.5	T35D40	3152	360	180	800	300	17	435	51
3.5	T35D50	3152	360	180	860	300	17	477	51
3.5	T35D20	3152	360	180	740	300	17	351	51
3.5	T35D30	3152	360	180	800	300	17	393	51
4	T40E40	3581	415	180	870	360	20	687	73
4	T40E50	3581	415	180	930	360	20	744	73
4	T40E20	3581	415	220	850	360	20	573	73
4	T40E30	3581	415	220	910	360	20	630	73

\*Pelarhöjden (H och h) kan mot tilläggspris ökas